

**SAILING INSTRUCTIONS**  
for the  
**Open Netherlands Championship**  
Spanker class  
Sailhorse class  
Javelin class  
and the  
**Open Netherlands class Championship**  
Efsix class

**organised by the Sailingclub Belterwiede**  
in conjunction with the Royal Netherlands Yachting Union  
from  
3 until and incl.6 September 2015  
on the Beulakewijde

---

[DP] denotes a rule for which the penalty is at the discretion of the International Jury.  
[NP] denotes that a breach of this rule will not be grounds for a protest by a boat.  
[SP] denotes a rule for which a standard penalty may be applied by the race committee without a hearing”

## **1. RULES**

- 1.1\* The regatta will be governed by the rules as defined in *The Racing Rules of Sailing*.
- 1.2\* The 'Rules for Championships Sailing, Windsurfing and will apply.
- 1.3 Prescriptions of the national authority will apply.
- 1.4 Class rules will not be changed.
- 1.5 If there is a conflict between languages the English text will take precedence.
- 1.6\* Every person on board who has its domicile in the Netherlands in shall have the required license
- 1.7

## **2. NOTICES TO COMPETITORS**

Notices to competitors will be posted on the official notice board(s) located at the race office.

## **3. CHANGES TO SAILING INSTRUCTIONS**

Any change to the sailing instructions will be posted before 09.00 on the day it will take effect, except that any change to the schedule of races will be posted by 20.00 on the day before it will take effect.

## **4. SIGNALS MADE ASHORE**

- 4.1 Signals made ashore will be displayed at the flagpole near the race office.



4.2 When flag AP  is displayed ashore, '1 minute' is replaced with 'not less than 45 minutes' in the race signal AP.

4.3 When flag Y  is displayed ashore, rule 40.1 applies at all times while afloat. This changes the Part 4 preamble

## 5 SCHEDULE OF RACES

5.1\* Dates of racing:

<i>Date</i>	<i>Races</i>	<i>remarks</i>
4 sept.	3 races	(Sailhorse only sail on Saturday and Sunday)
5 sept.	4 races	
6 sept.	3 races	

Start sequence is:

Javelin, Spanker, Sailhorse, Efsix.

5.2 One extra race per day may be sailed, provided that no class becomes more than one race ahead of schedule.

5.3\* The scheduled time of the warning signal for the first race each day is:

Friday 4 sept. 11.25 h

Saturday 5 sept. 09.55 h

Sunday 6 sept. 10.25 h

5.4 To alert boats that a race or sequence of races will begin soon, an orange flag will be displayed with one sound for at least four minutes before a warning signal is displayed.

5.5 On the last day of the regatta no warning signal will be made after 15.00 h.

## 6\* CLASS FLAGS

Class flags will be:

<i>Class</i>	<i>Flag</i>
Javelin	"O" (Oscar)
Spanker	"D" (delta)
Sailhorse	"F" (foxtrot)
Efsix	"K" (Kilo)

## 7 RACING AREAS

Attachment "A" shows the location of racing areas.

## 8 THE COURSES

8.1\* The diagrams in Attachment "B", show the trapezium courses, the order in which marks are to be passed, and the side on which each mark is to be left.  
The approximate course length will be 50 minutes

**8.2** No later than the warning signal, the race committee signal boat will display the approximate compass bearing of the first leg.

## **9 MARKS**

**9.1\*** Marks of the course are: Yellow and have a cylindrical shape.

**9.2** New marks, as provided in instruction 12.1, will be Orange and have a cylindrical shape .

**9.3\*** The starting and finishing marks will be as described in SI 11.2 and SI 13.

**9.4** A race committee boat signaling a change of a leg of the course is a mark as provided in instruction 12.2.

## **10 RESERVE**

## **11 THE START**

**11.1** Races will be started by using rule 26 with the warning signal given 5 minutes before the starting signal.

**11.2\*** The starting line will be between a staff displaying an orange flag on the starting vessel at the starboard-end and a staff displaying an orange flag on the mark at the port-end of the line.

**11.3** Boats whose warning signal has not been made shall avoid the starting area.

**11.4** A boat starting later than 4 minutes after her starting signal will be scored Did Not Start. This changes rule A4 and A5.

**11.5** If flag U  as the preparatory signal has been displayed no part of a boat's hull, crew, or equipment shall be in the triangle formed by the ends of the starting line and the first *mark* during the last minute before her starting signal. If a boat breaks this rule and is identified, she shall be disqualified without a hearing but not if the race is restarted or resailed. This changes rule 26, starting races, and A5. When flag U is used as the preparatory signal rule 29.1, Individual recall, does not apply. The scoring abbreviation for a flag U penalty is UFD. This changes A11 Scoring Abbreviations.

## **12 CHANGE OF THE NEXT LEG OF THE COURSE**

**12.1** To change the next leg of the course, the race committee will lay a new mark (or move the finishing line) and remove the original mark as soon as practicable. When in a subsequent change a new mark is replaced, it will be replaced by an original mark.

**12.2** Boats shall pass between the race committee boat signalling the change of the next leg and the nearby mark, leaving the mark to port and the race committee boat to starboard. This changes rule 28.1.

## **13\* THE FINISH**

The finishing line will be between a staff displaying an orange flag on the finishing mark at the starboard end and a blue flag on board of the finishing vessel on the port -end.

## **14 RESERVE**

## 15 TIME LIMITS AND TARGET TIMES

15.1 Time limits are as follows:

*Time limit Mark 1*      *target time*

*20 minutes*              *50 minutes*

If no boat has passed Mark 1 within the Mark 1 time limit the race will be abandoned.

15.2 Failure to meet the target time will not be grounds for redress. This changes rule 62.1(a).

15.3 Boats failing to finish within 20 minutes after the first boat sails the course and finishes will be scored Did Not Finish without a hearing. This changes rules 35, A4 and A5.

## 16 PROTESTS AND REQUESTS FOR REDRESS

16.1 Protest forms are available at the race office located Race office. Protests shall be delivered there within the protest time limit.

16.2 For each class, the protest time limit is 45 minutes after the last boat has finished the last race of the day or the race committee signals no more racing today, whichever is later.

16.3 Notices will be posted within 30 minutes of the protest time limit to inform competitors of hearings in which they are parties or named as witnesses. Hearings will be held in the jury room, located at at the race office.

16.4 Notices of protests by the race committee or protest committee will be posted to inform boats under rule 61.1(b).

16.5 Breaches of instructions marked with [DP] will not be grounds for a protest by a boat. This changes rule 60.1(a). Penalties for these breaches may be less than disqualification if the protest committee so decides.

16.6 On the last day of the regatta a request for reopening a hearing shall be delivered  
(a) within the protest time limit if the party requesting reopening was informed of the decision on the previous day;  
(b) no later than 30 minutes after the party requesting reopening was informed of the decision on that day.  
This changes rule 66.

16.7 On the last scheduled day of racing a request for redress from a protest committee decision shall be delivered no later than 30 minutes after the decision was posted. This changes rule 62.2.

16.8 A request for a decision in writing has to be delivered within one hour after the decision is given verbally. This changes rule 65.2.

16.9 A request for correction of an error in the published results has to be delivered within the protest time limit of the last scheduled day of racing or within 60 minutes after posting of the results, if this is later. When the request is not granted, the protest time limit is 60 minutes after the boat is informed that the request is not granted. This changes rule 62.2.

## 17 SCORING

17.1\* Four races are required to be completed to constitute a series.

17.2 (a) When fewer than 5 races have been completed, a boat's series score will be the total of her race scores.  
(b) When 5 or 10 races have been completed, a boat's series score will be the total of her race scores excluding her worst score



## **18 [NP][DP] SAFETY REGULATIONS**

**18.1** A boat that retires from a race shall notify the race committee as soon as possible.

## **19 REPLACEMENT OF CREW**

**19.1\*** Substitution of competitors will not be allowed without prior written approval of the race committee. Replacement of the responsible person is not allowed.

## **20 EQUIPMENT AND MEASUREMENT CHECKS**

A boat or equipment may be inspected at any time for compliance with the class rules and sailing instructions. On the water, a boat can be instructed by the race committee or a measurer to proceed immediately to a designated area for inspection.

## **21 RESERVE**

## **22 OFFICIAL BOATS**

Official boats will be marked as follows: .

- orange flag marked with "W"
- yellow flag marked with "R"

## **23 [NP][DP] SUPPORT BOATS**

**23.** Team leaders, coaches and other support personnel shall stay outside areas where boats are racing from the time of the preparatory signal for the first start until all boats have finished or retired or the race committee signals a postponement, general recall or abandonment.

## **24 [NP][DP] TRASH DISPOSAL**

Trash may be placed aboard support and race committee boats. A penalty for breaking rule 55 may be less than disqualification if the protest committee so decides. This changes rule 64.1.

## **25 [NP][DP] HAUL-OUT RESTRICTIONS**

Keel boats shall not be hauled out during the regatta except with and according to the terms of prior written permission of the race committee.

## **26 [NP][DP] DIVING EQUIPMENT AND PLASTIC POOLS**

Underwater breathing apparatus and plastic pools or their equivalent shall not be used around keelboats between the preparatory signal of the first race and the end of the regatta.

## **27 [NP][DP] RADIO COMMUNICATION**

A boat shall neither make radio transmissions while racing nor receive radio communications not available to all boats. This restriction also applies to mobile telephones. VHF will only be used for safety communication.

## **28\* PRIZES**

Helmsman and crew of the winning boat of the championship acquire the title "Dutch Champion" and receive the accompanying medal(s) of the RNLYU.

The responsible person and the crew of the winning boat acquires the Blue Pennant of the RNLYU.



Helmsman and crew of the boats that are places second and third acquire also medal(s) of the RNLYU.

Helmsman and crew of the winning boat of the Class championship acquire the title "Class Champion" . and receive the accompanying medal(s) of the RNLYU

The responsible person and crew of the winning boat acquires the Red Pennant of the RNLYU.

Helmsman and crew of the boats that are places second and third acquire also medal(s) of the RNLYU.

Other prizes will be given by the class organisations.

## **29 DISCLAIMER OF LIABILITY**

Competitors participate in the regatta entirely at their own risk. See rule 4, Decision to Race. The organizing authority will not accept any liability for material damage or personal injury or death sustained in conjunction with or prior to, during, or after the regatta.

## **30 INSURANCE**

Each participating boat shall be insured with valid third-party liability insurance with a minimum cover of Euro 1.500.000 per event or the equivalent.

## **31 ORGANISATION**

The race officer is Theo Souren

The chairman of the protest committee is: Peter Nannenber

The by the RNLYU appointed equipment inspectors are Willem Slenderbroek and Arent de Jong, who are in study for class measurer/inspector and they will be guided by the "head measurement" of the RNLYU , Michiel Woort.

The inspectors for the Efsix are Rob Thonus and Wybe Slot.

## **ATTACHMENT "A"**

Showing the location of the race area

## **ATTACHMENT "B"**

Showing the trapezium courses

**Attachment A**

A= Regatta harbour B= Racing area

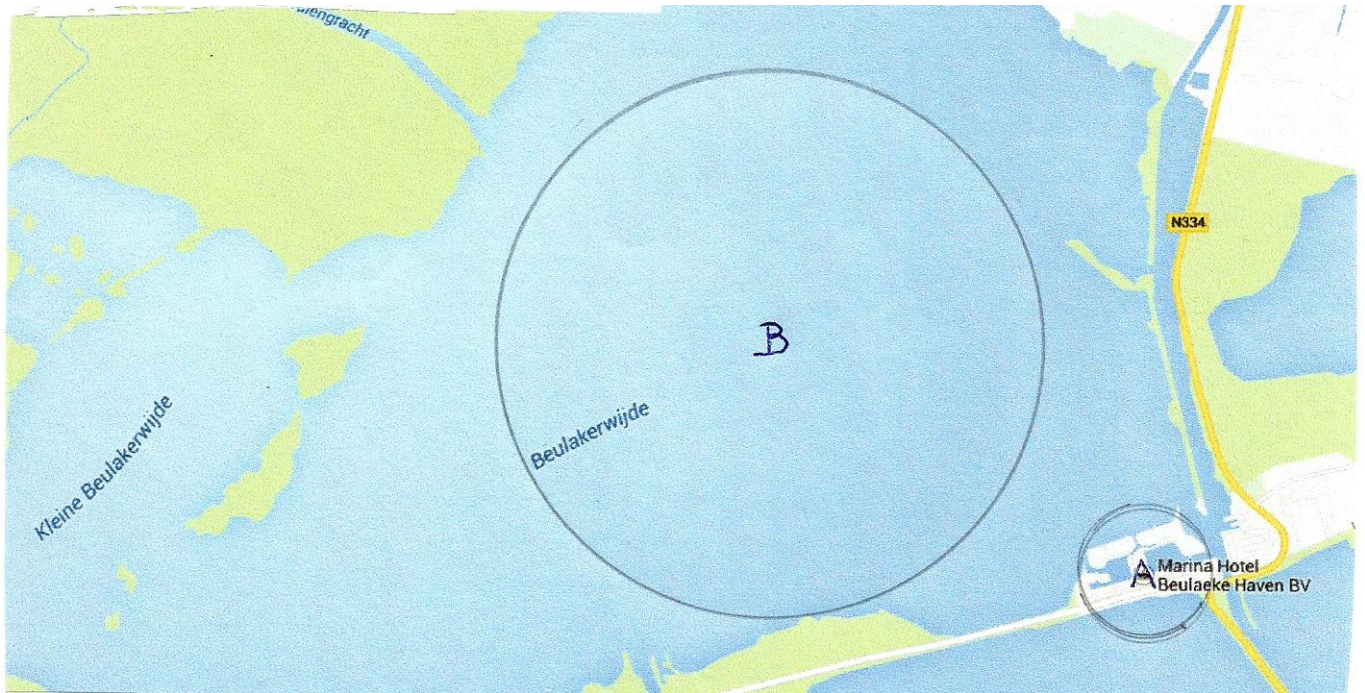

ATTACHMENT "B"

COURSE 1

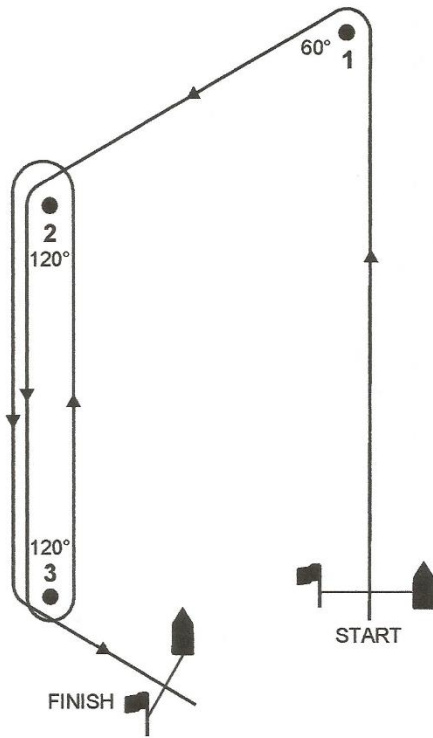

Start - 1 - 2 - 3 - 2 - 3 - Finish

COURSE 3

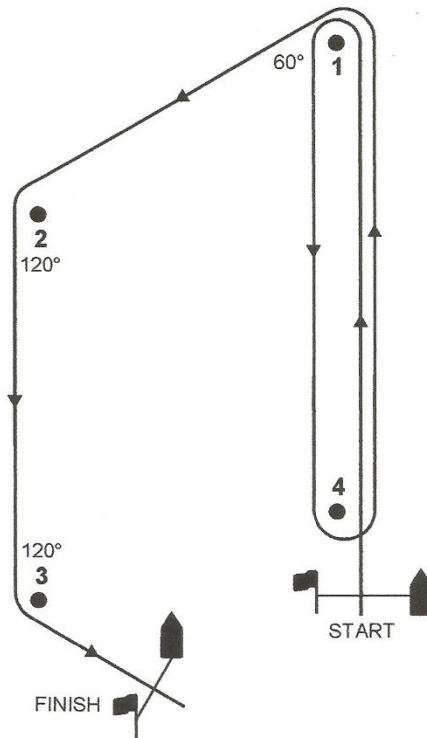

Start - 1 - 4 - 1 - 2 - 3 - Finish

Wedstrijden 2015 Final



ATTACHMENT "B"

COURSE 2

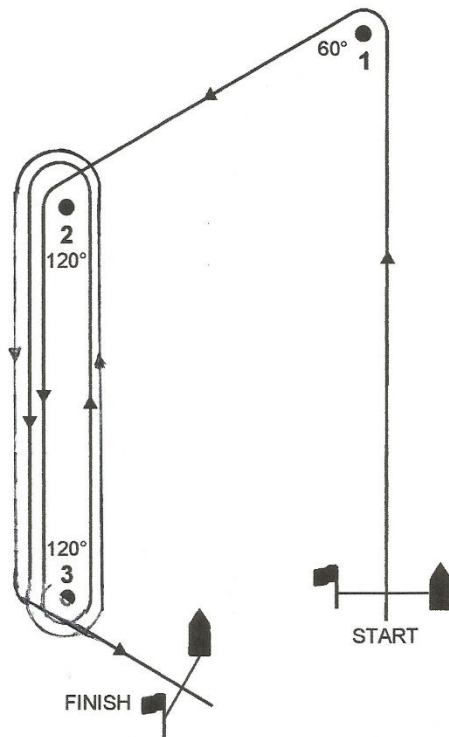

Start - 1 - 2 - 3 - 2 - 3 - 2 - 3 - Finish

COURSE 4

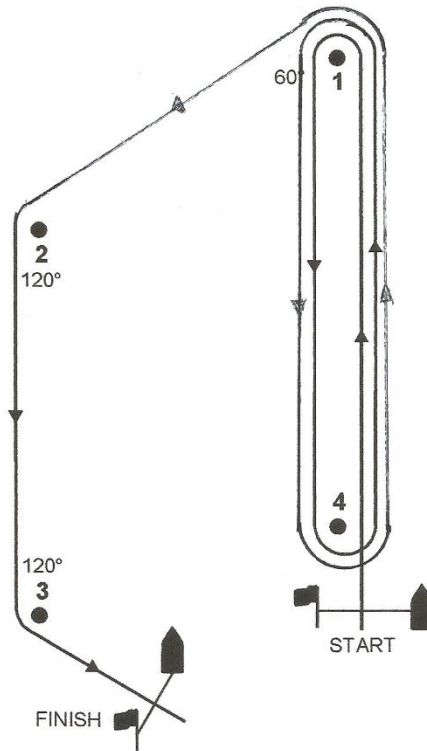

Start - 1 - 4 - 1 - 4 - 1 - 2 - 3 - Finish

Wedstrijden 2015 Final